

Aquaplus

**SDG Series
Submersible
Dewatering Pumps
240V**



Dewatering Pumps

**1 Year
Warranty!**

Submersible Dewatering Pumps 240V

Aquaplus SDG Series 240V pumps are small robust dewatering pumps ideal for professional use in applications such as storm water drainage and aquaculture. These units have vertical floats and can be operated in manual or automatic mode.

Features

- Single phase 240V pump
- Small robust pump
- Automatic motor protection
- Double mechanical seal in oil bath
- Reinforced polymer / non-corrosive housing
- Manual / auto vertical float
- Maximum water temperature 40°C
- Impeller type - open

Applications

- Suitable for sea water
- Cellar or basement drainage
- Storm water drainage
- Tank / pool / pond pump out / circulation
- Fish breeding / aquaculture
- Emergency pump out down to 2mm (SDG-25-2A-.1S2-10AVP-O)

Specifications

Model Number	Discharge (mm)	Power (kW)	Voltage (V)	Cable (m)	Max Flow (LPM)	Shut-off Head (m)	Pump Weight (kg)	Max Solid (mm)	Rated current A (240 V)
Automatic / Manual									
SDG-25-2A-.1S2-10AVP-O	25	0.1	230	10	95	6.5	4.1	2	1.01
SDG-50-2A-.4S2-10AVP-O	50	0.4	220	10	315	10	9.1	2.5	3.4

Dimensions

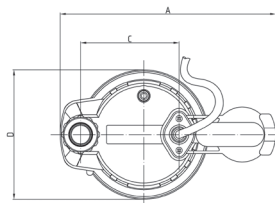

SDG-25-2A-.1S2-10AVP-O

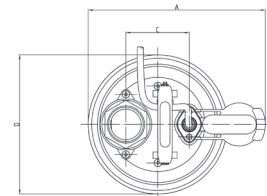

SDG-50-2A-.4S2-10AVP-O

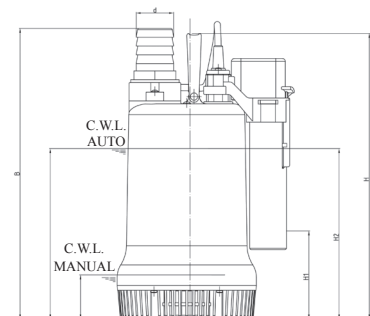
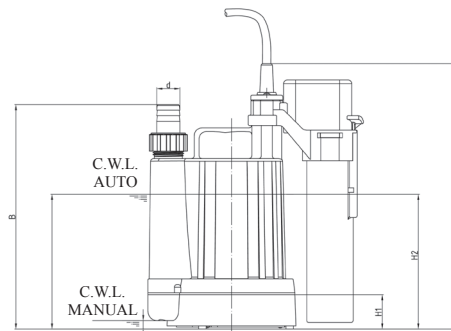

Model	Dimensions (mm)									
	D	H	A	B	C	H1	H2	d	C.W.L. Manual	C.W.L. Auto
Automatic / Manual										
SDG-25-2A-.1S2-10AVP-O	139	286	232	242	106	38	140	19/25	2	145
SDG-50-2A-.4S2-10AVP-O	190	390	242	397	86.5	102	230	50	60	233

All content is subject to change without notice.

Performance Curves

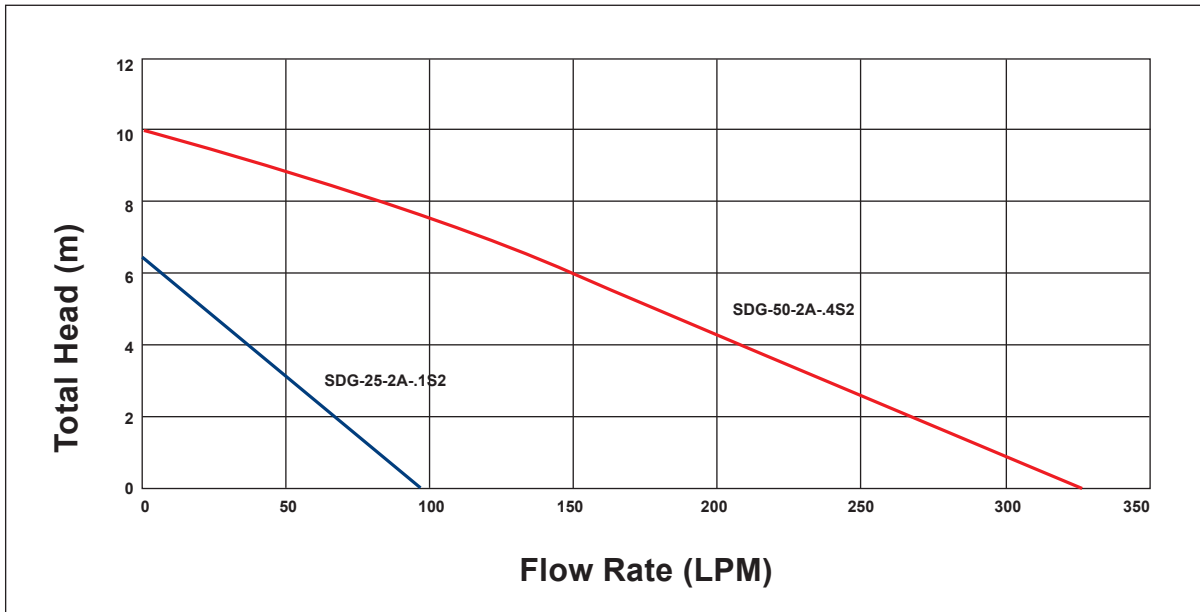

Materials of construction

	SDG25-2A		SDG-50-2A	
Impeller	Plastic		Plastic	
Casing	Plastic		Plastic	
Suction Plate	Plastic		Plastic	
Motor frame	Aluminium		Aluminium	
Shaft	316 stainless steel		316 stainless steel	
Fasteners	316 stainless steel		316 stainless steel	
Elastomers	FPM		FPM	
Mechanical seal	Primary seal	Carbon/Ceramic	Primary seal	Carbon/Ceramic
	Secondary seal	N/A	Secondary seal	Carbon/Ceramic

Other Submersible Dewatering and Drainage Pumps

The Aquaplus product range also features heavy duty submersible dewatering pumps suitable for industrial applications:

SDB Series - Aquaplus SDB 240V pumps are small robust dewatering pumps ideal for professional use in applications such as construction sites and site drainage. SDB pumps are designed for continuous unattended operation. Manual and automatic (with float) versions are available.

SD Series - Aquaplus SD Series 415V pumps are used extensively in applications such as construction dewatering and sump drainage. SD Series pumps are designed for continuous unattended operation.

SDA Series - Aquaplus SDA Series 415V pumps has an agitator and are used extensively in applications such as construction dewatering and sump drainage. SDA Series pumps are designed for continuous unattended operation.

SDL Series - Aquaplus SDL Series 415V pumps are applied when higher heads or flow rates are required and are used in applications such as general construction works, civil engineering, deep well applications and mine site dewatering.

All content is subject to change without notice.

Aquaplus Product Range

ESD Series – End Suction DIN (24255) Pumps

ESI Series – End Suction ISO (2585) Pumps

SP Series – Self Priming Pumps

SD Series – Submersible Dewatering Pumps

AD Series – Air Diaphragm Pumps

MD Series – Magnetic Drive Pumps

FRM Series – Flexible Rising Main (Borehole Pump Hose)

MS Series – Mechanical Seals (Single Spring & Cartridge)

We are also able to provide Progressive Cavity, Peristaltic Pumps, Split Case Pumps and Magnetic Drive Pumps.

The logo for Aquaplus, featuring the word "aquaplus" in a stylized, blue, lowercase font with a wave-like graphic element above the 'a'.

AVAILABLE FROM

For information on these products or for any specialised requirements please contact your local Aquaplus distributor or visit our website at www.aquapluspumps.com.au