

Aquaplus

**ARS Series
Submersible Aerators**



Submersible Aerators

**2 Year
Warranty!**

Aquaplus ARS Series Submersible Aerators mix microscopic air bubbles into the water, producing a high oxygen transfer rate. They are ideal for aeration applications in waste water treatment plants, sewage treatment plants, agricultural industries and the prevention of sedimentation.

Features

- Double mechanical seal
- Produces microscopic bubbles (high oxygen transfer rate)
- Submersible motor, low noise, high efficiency
- Twelve radiated outlets
- Integrated stainless steel strainer prevents impeller from being blocked by foreign material
- Large air intake
- Guide rail available for easy installation, maintenance and repair

Applications

- Aeration, pre-aeration and/or mixing in:
- Industrial waste water treatment plants
 - Sewage treatment plants
 - Effluent in agricultural industries
 - Prevention of sedimentation



Dimensions

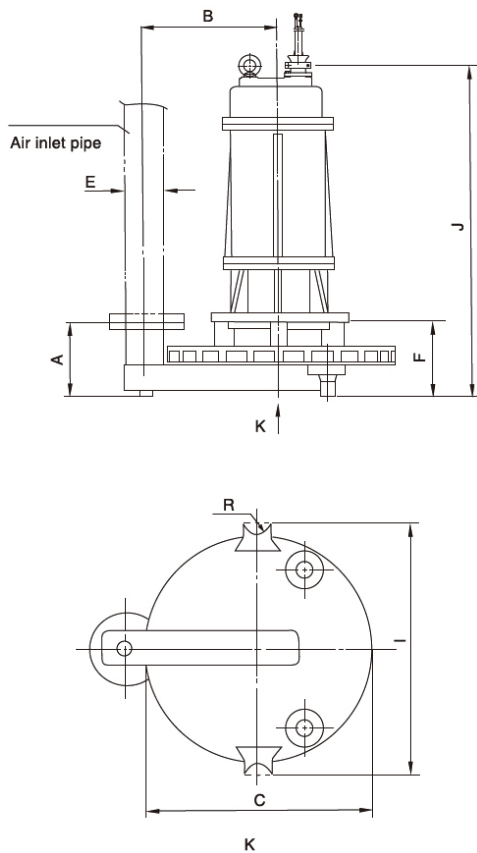

| Part Number | Dimensions (mm) | | | | | | | |
|----------------------|-----------------|-----|-----|-----|-----|------|------|----|
| | A | B | C | E | F | I | J | R |
| ARS-40-11-1.5T4-20 | 155 | 300 | 505 | 40 | 152 | 565 | 597 | 30 |
| ARS-50-11-2.2T4-20 | 155 | 300 | 505 | 50 | 154 | 565 | 677 | 30 |
| ARS-65-11-3.7T4-20 | 155 | 300 | 505 | 65 | 156 | 565 | 694 | 30 |
| ARS-65-11-5.5T4-20 | 203 | 410 | 685 | 65 | 218 | 745 | 871 | 30 |
| ARS-80-11-7.5T4-20 | 203 | 410 | 685 | 80 | 221 | 745 | 874 | 30 |
| ARS-80-11-11T4-20 | 203 | 410 | 685 | 80 | 223 | 745 | 931 | 30 |
| ARS-100-11-15T4-20 | 203 | 410 | 685 | 100 | 225 | 745 | 973 | 30 |
| ARS-100-11-18.5T4-20 | 203 | 410 | 685 | 100 | 228 | 745 | 1097 | 30 |
| ARS-100-11-22T4-20 | 203 | 410 | 685 | 100 | 228 | 745 | 1097 | 30 |
| ARS-150-11-30T4-20 | 338 | 600 | 950 | 150 | 384 | 1028 | 1474 | 39 |
| ARS-150-11-37T4-20 | 338 | 600 | 950 | 150 | 384 | 1028 | 1474 | 39 |
| ARS-150-11-45T4-20 | 338 | 600 | 950 | 150 | 384 | 1028 | 1474 | 39 |
| ARS-150-11-55T4-20 | 338 | 600 | 950 | 150 | 384 | 1028 | 1474 | 39 |

Specifications

| Part Number | Discharge (kg O ₂ /h) | Power | | Pole (P) | Max Solids (mm) | Air Capacity @ 3m Depth (m ³ /h) | Max Depth (m) | Dry Weight (kg) |
|----------------------|----------------------------------|-------|------|----------|-----------------|---|---------------|-----------------|
| | | Hp | kW | | | | | |
| ARS-40-11-1.5T4-20 | 2 - 1 | 2 | 1.5 | 4 | 11.5 x 33.5 | 30 | 3.0 | 104 |
| ARS-50-11-2.2T4-20 | 3 - 2 | 3 | 2.2 | 4 | 11.5 x 33.5 | 40 | 4.0 | 117 |
| ARS-65-11-3.7T4-20 | 5 - 3 | 5 | 3.7 | 4 | 11.5 x 33.5 | 80 | 4.0 | 132 |
| ARS-65-11-5.5T4-20 | 9 - 5 | 7.5 | 5.5 | 4 | 11.5 x 37 | 128 | 4.0 | 279 |
| ARS-80-11-7.5T4-20 | 13 - 7 | 10 | 7.5 | 4 | 11.5 x 37 | 170 | 4.5 | 286 |
| ARS-80-11-11T4-20 | 18 - 8 | 15 | 11 | 4 | 11.5 x 37 | 265 | 4.6 | 340 |
| ARS-100-11-15T4-20 | 23 - 10 | 20 | 15 | 4 | 11.5 x 37 | 330 | 4.8 | 355 |
| ARS-100-11-18.5T4-20 | 29 - 14 | 25 | 18.5 | 4 | 11.5 x 37 | 385 | 5.0 | 405 |
| ARS-100-11-22T4-20 | 36 - 19 | 30 | 22 | 4 | 11.5 x 37 | 470 | 5.5 | 420 |
| ARS-150-11-30T4-20 | 41 - 21 | 40 | 30 | 4 | 11.5 x 37 | 510 | 6.0 | 1000 |
| ARS-150-11-37T4-20 | 52 - 22 | 50 | 37 | 4 | 11.5 x 37 | 570 | 6.0 | 1080 |
| ARS-150-11-45T4-20 | 62 - 25 | 60 | 45 | 4 | 11.5 x 37 | 630 | 6.0 | 1150 |
| ARS-150-11-55T4-20 | 82 - 40 | 75 | 55 | 4 | 11.5 x 37 | 825 | 6.0 | 1200 |

Performance Curves

Air Emission Volume/Water Depth

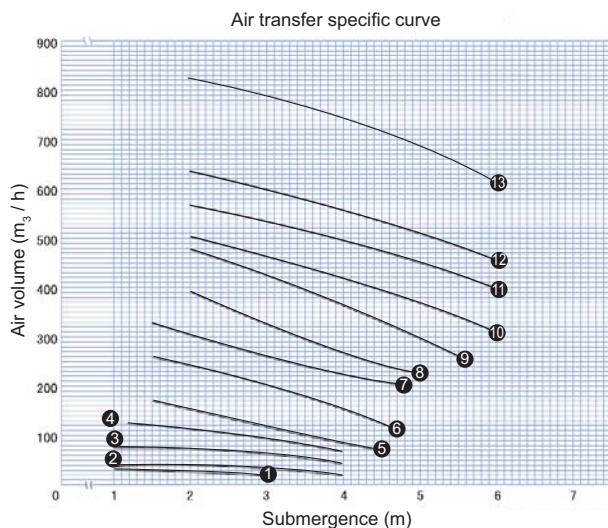

Oxygen Transfer/Water Depth

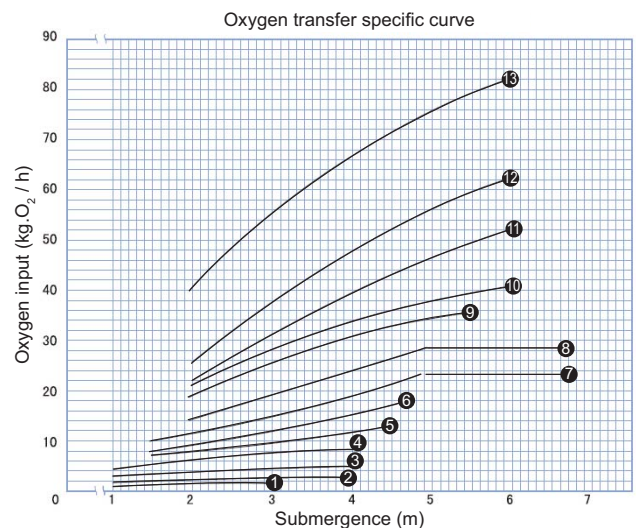

IMPORTANT: Pump curves are guidelines only. Before making a product selection please contact your local Aquaplus pump distributor for a detailed pump curve of each model.

Legend:

- ① ARS-40-11-1.5T4-20
- ② ARS-50-11-2.2T4-20
- ③ ARS-65-11-3.7T4-20
- ④ ARS-65-11-5.5T4-20
- ⑤ ARS-80-11-7.5T4-20
- ⑥ ARS-80-11-11T4-20
- ⑦ ARS-100-11-15T4-20
- ⑧ ARS-100-11-18.5T4-20
- ⑨ ARS-100-11-22T4-20
- ⑩ ARS-150-11-30T4-20
- ⑪ ARS-150-11-37T4-20
- ⑫ ARS-150-11-45T4-20
- ⑬ ARS-150-11-55T4-20



AVAILABLE FROM

For information on these products or for any specialised requirements
please contact your local Aquaplus distributor or visit our
website at www.aquapluspumps.com.au